

Vue générale de la solution retenue

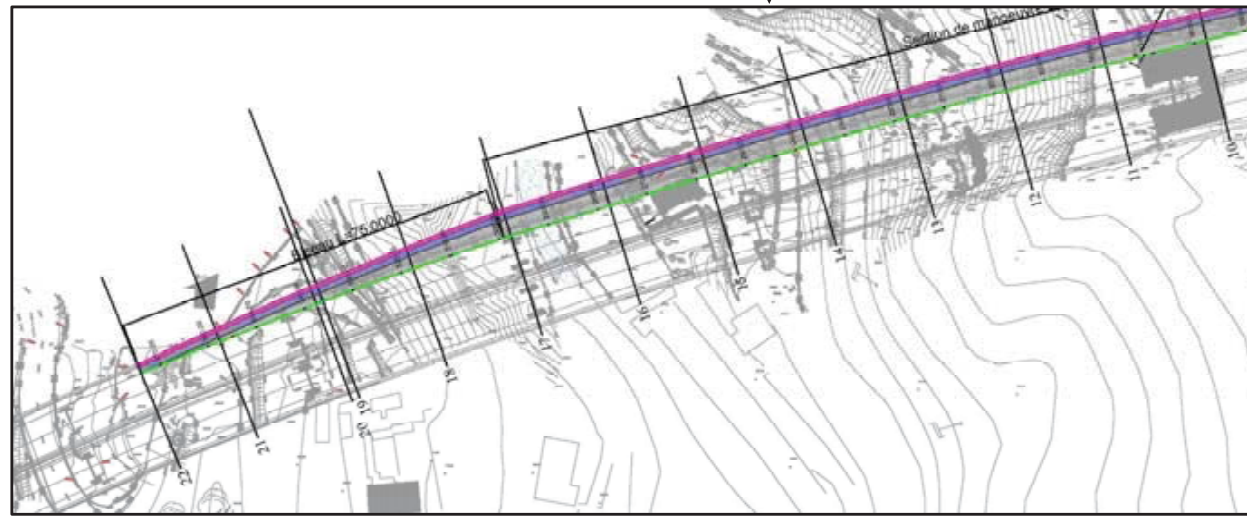

Aménagement du viaduc

Aménagement de la bretelle d'insertion et de la RD

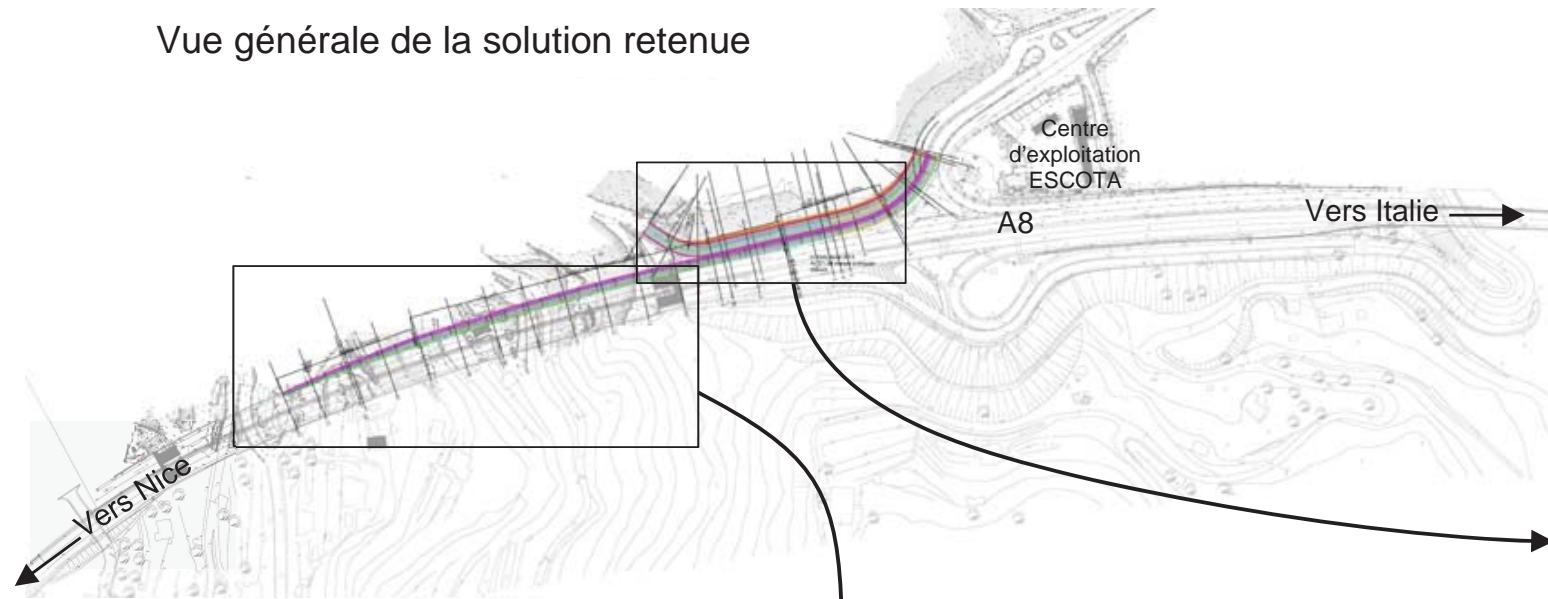
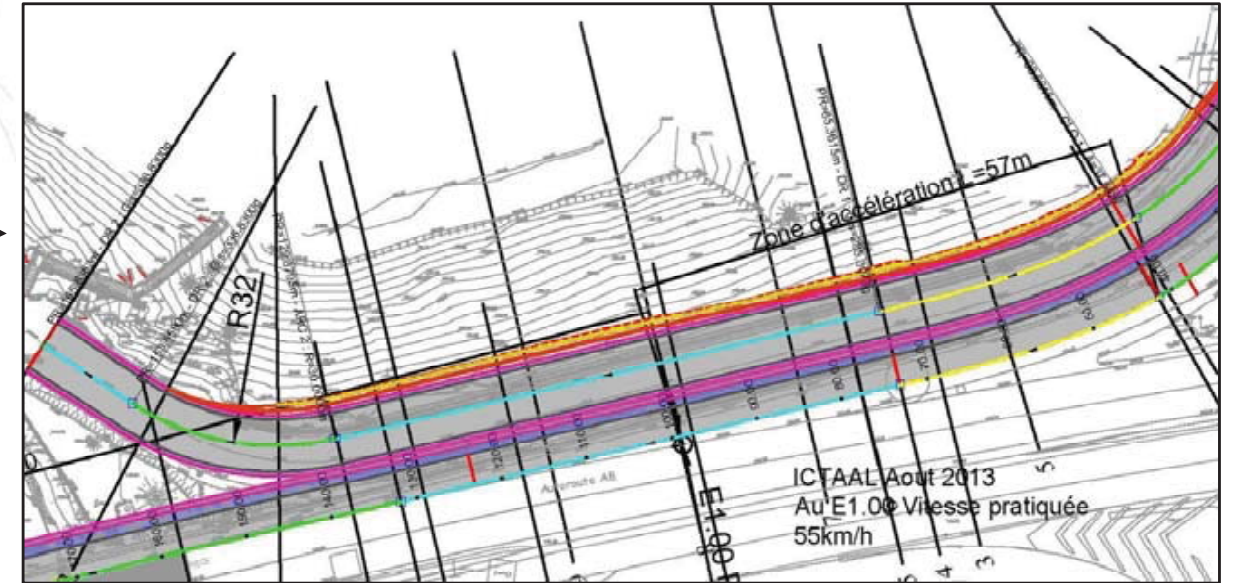

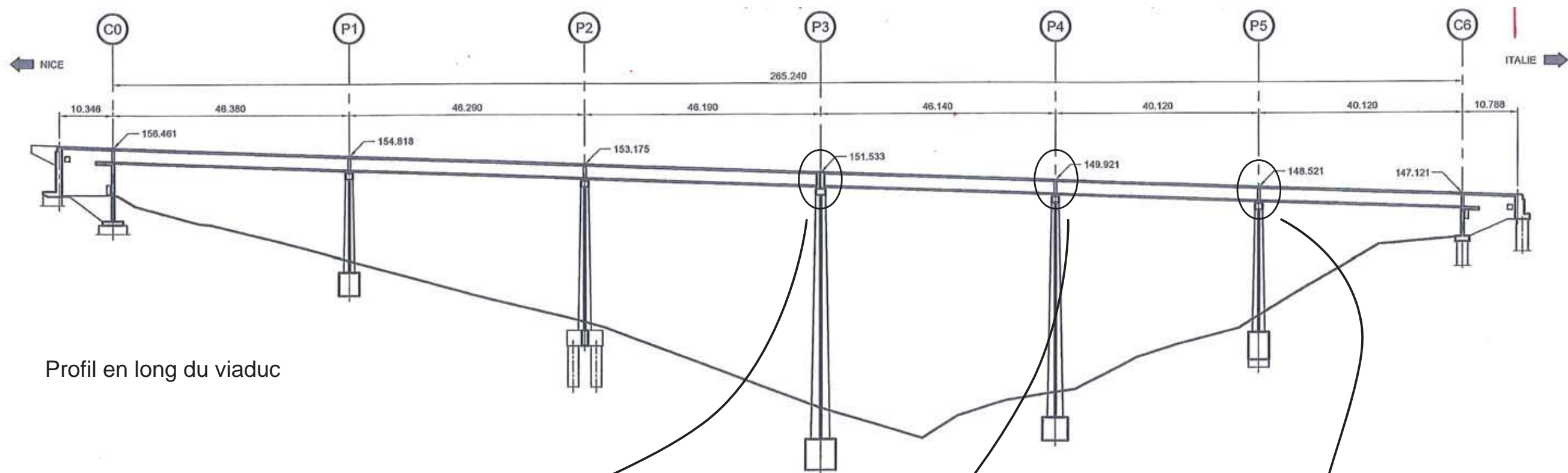

Profil en long du viaduc

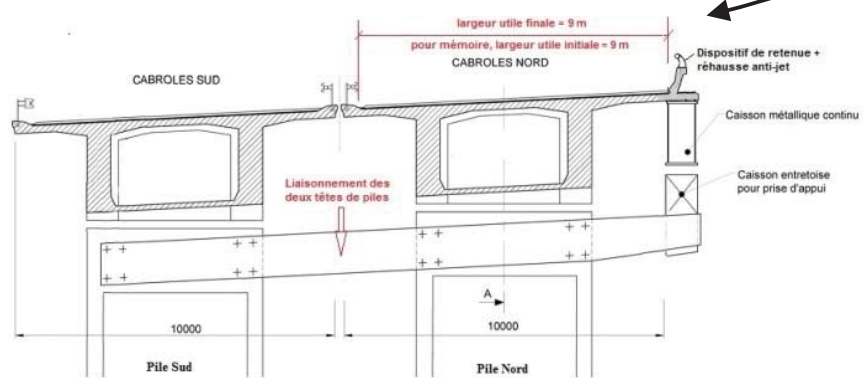

Coupe terminale de principe du biseau

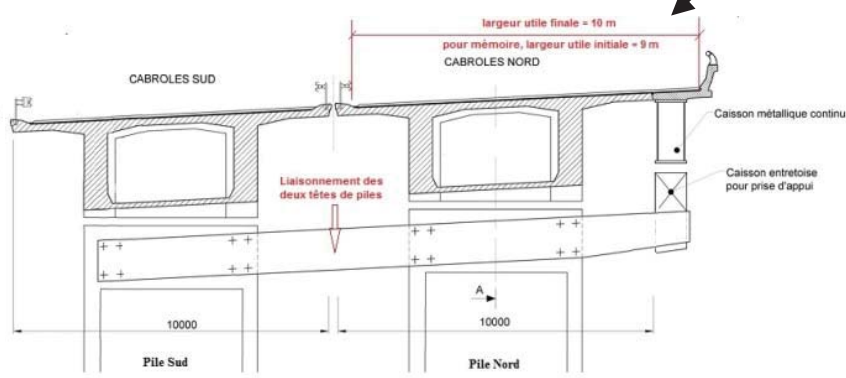

Coupe intermédiaire de principe du biseau

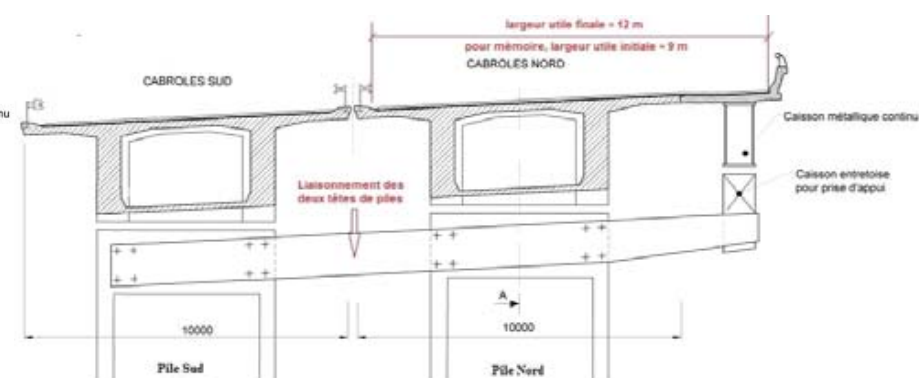

Coupe de principe de l'élargissement du tablier